

LCD Controller Board (AD Board)

An AD board is a TFT LCD controller board which act as an interface between the TFT LCD and PC systems, the AD board transfers the image created from the PC to the TFT screen.

AD Board works with input connections such as VGA, HDMI, DVI or DP (Display Port).

Bolymin provide AD board with cable assembly that is customized to customer's requirement. Bolymin LCD Controller Board can be used for wide range of applications, industrial display, medical equipment, POS, railways display, Digital Signage, and Kiosk.



[download flyer](#)



[download flyer](#)



Transfer/ Converter Board for TFT LCD

TFT LCD Transfer/ Converter board allow making a connection between TFT and PCBA when the interface is different/ incompatible.

Bolymin Provide RGB to LVDS Transfer/ Converter board

HDMI to LVDS Transfer/ Converter board

Description	Outline Dimension (mm)	Drive IC
input interface LVDS to output interface RGB	50x35	THC63LVDF84C
input interface RGB to output interface LVDS	54x50	THC63LVDM83D

BT5450ASA1\$



Feature

1. RGB to LVDS Interface board.
2. Compatible with TIA/EIA-644 LVDS Standard
3. Pixel Clock Range: 8 to 160MHz
4. Operating temperature :-20 to 70 °C
5. LVDS swing is reducible as 200mVbyRS-pin to reduce EMI and power consumption.
6. Option: Backlight driving up to 200mA.

General Spec.

Module Dimension	54.0 x 50.0 mm
Driver IC	THC63LVDM83D
Input interface	RGB 24 BITS
Output interface	LVDS

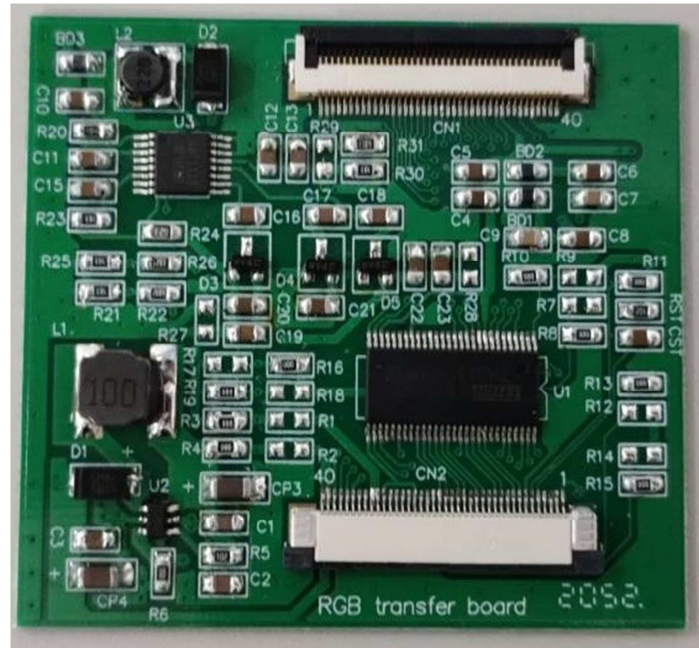

Dimension

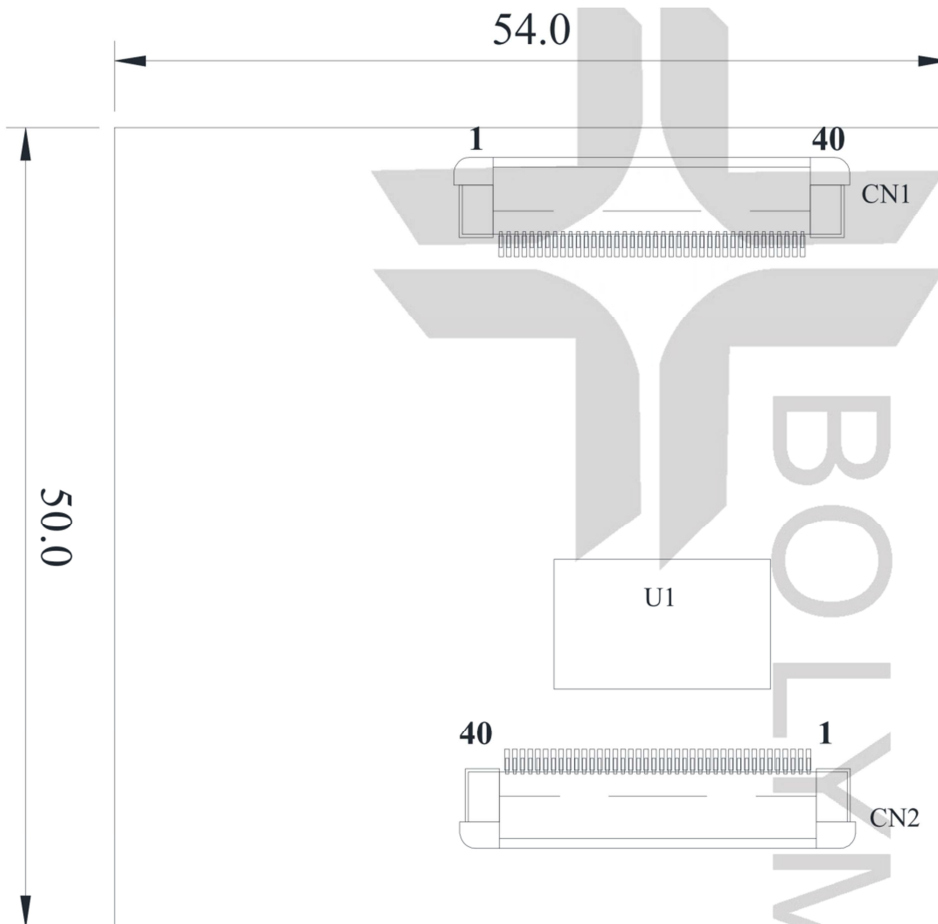

Pin assignment (Input)

Pin No.	Symbol	Function
1	LED-	LED Cathode
2	LED+	LED Anode.
3	GND	Ground.
4	VDD	Power supply input.
5~12	R0~R7	8-bit digital RED data input.
13~20	G0~G7	8-bit digital Green data input.
21~28	B0~B7	8-bit digital BLUE data input.
29	GND	Ground.
30	CLK	Clock signal .
31	DISP	Output High.
32	HYSNC	Horizontal sync signal.
33	VSYNC	Vertical sync signal.
34	DEN	Data input enable.
35	NC	No connection.
36	GND	Ground.
37~40	NC	No connection.

Note 1: This board also could provide TFT panel backlight driving current by provide LED+ =5V & LED-=GND. Please contact Bolymin's sales for this function.

Pin assignment (Output)

Pin No.	Symbol	Function
1	VCOM	Power for VCOM (2.7~3.3V)
2,3	VDD	Power supply output.
4	NC	No connection.
5	/RST	Global reset pin, pulled high.
6	STBYB	Standby mode, pulled high.
7	GND	Ground.
8	RX0-	-LVDS differential data output.
9	RX0+	+LVDS differential data output.
10	GND	Ground.
11	RX1-	-LVDS differential data output.
12	RX1+	+LVDS differential data output.
13	GND	Ground.
14	RX2-	-LVDS differential data output.
15	RX2+	+LVDS differential data output.
16	GND	Ground.
17	RXCLK-	-LVDS differential clock output.
18	RXCLK+	+LVDS differential clock output.
19	GND	Ground.
20	RX3-	-LVDS differential data output.
21	RX3+	+LVDS differential data output.
22	GND	Ground.
23,24	NC	No connection.
25	GND	Ground.
26	NC	No connection.
27	DIM	Backlight dimming control.
28	NC	No connection.
29	AVDD	Power for analog circuit.
30	GND	Ground.
31,32	LED-	LED Cathode
33~34	NC	No connection.
35	VGL	Power for Gate off voltage.
36	CAB1	Output High.
37	CAB0	Output Low.
38	VGH	Power for Gate on voltage.
39,40	LED+	LED Anode.



BT5035ASA1\$

Feature

1. LVDS to RGB Interface board.
2. No Special Start-up Sequence Required
3. Pixel Clock Range: 8 to 112MHz
4. Operating temperature :-20 to 70 °C
5. Option: Backlight driving up to 200mA.

General Spec.

Module Dimension	50.0 x 35.0 mm
Driver IC	THC63LVDF84C
Input interface	LVDS
Output interface	RGB 24 BITS

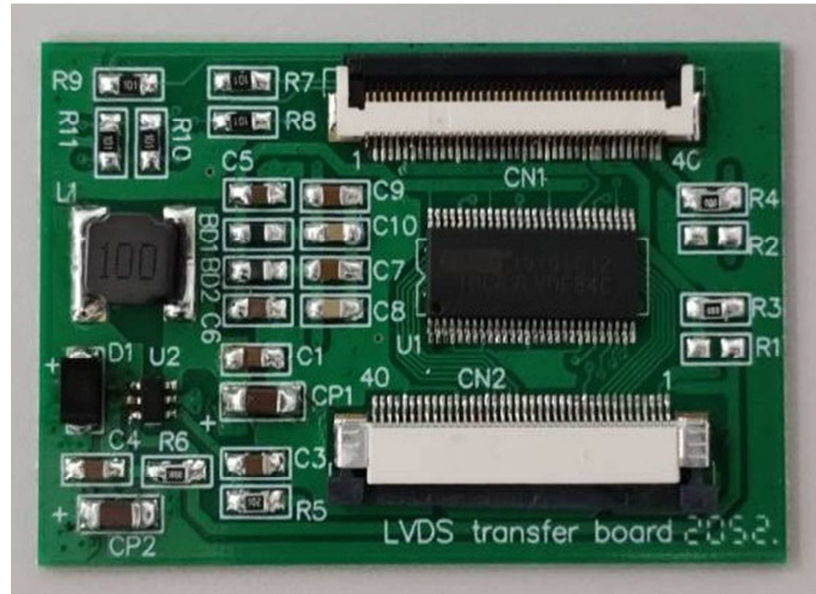

Dimension

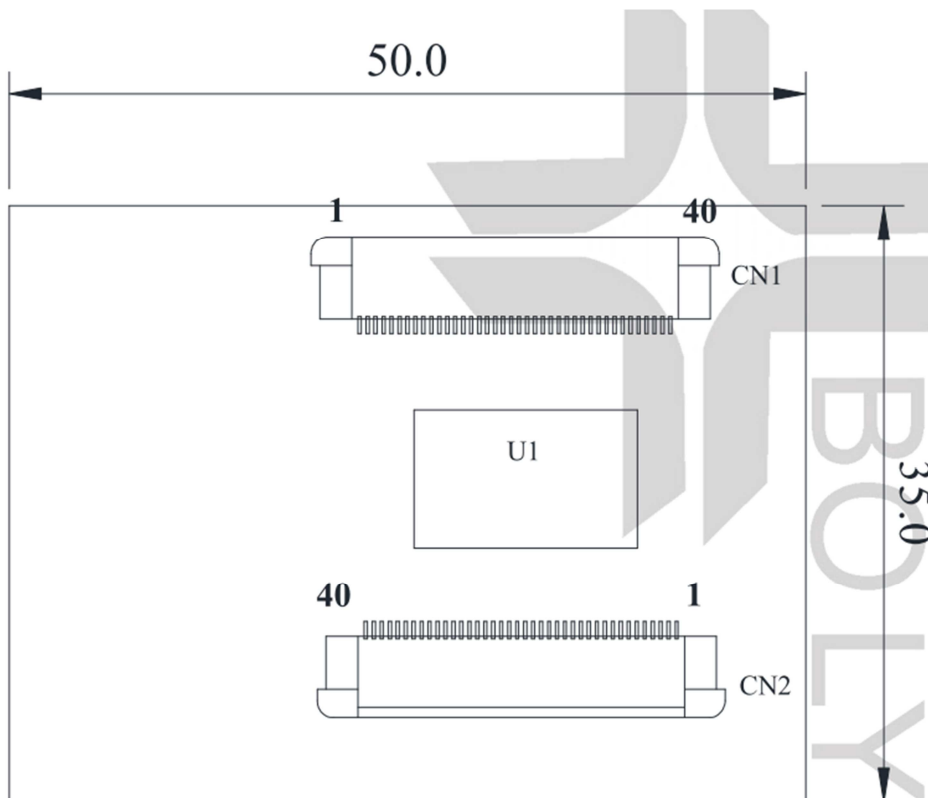

Pin assignment (Input)

Pin No.	Symbol	Function
1	NC	No connection.
2,3	VDD	Power supply input.
4~6	NC	No connection.
7	GND	Ground.
8	RA-	-LVDS differential data input.
9	RA+	+LVDS differential data input.
10	GND	Ground.
11	RB-	-LVDS differential data input.
12	RB+	+LVDS differential data input.
13	GND	Ground.
14	RC-	-LVDS differential data input.
15	RC+	+LVDS differential data input.
16	GND	Ground.
17	RCLK-	-LVDS differential clock input.
18	RCLK+	+LVDS differential clock input.
19	GND	Ground.
20	RD-	-LVDS differential data input.
21	RD+	+LVDS differential data input.
22	GND	Ground.
23,24	NC	No connection.
25	GND	Ground.
26~29	NC	No connection.
30	GND	Ground.
31,32	LED-	LED Cathode
33~38	NC	No connection.
39,40	LED+	LED Anode.

Pin assignment (Output)

Pin No.	Symbol	Function
1	LED-	LED Cathode
2	LED+	LED Anode.
3	GND	Ground.
4	VDD	Power supply input.
5~12	R0~R7	8-bit digital RED data output.
13~20	G0~G7	8-bit digital Green data output.
21~28	B0~B7	8-bit digital BLUE data output.
29	GND	Ground.
30	CLK	Pixel Clock signal
31	DISP	Output High.
32	HYSNC	Horizontal sync signal..
33	VSYNC	Vertical sync signal.
34	DEN	Data input enable.
35	NC	No connection.
36	GND	Ground.
37~40	NC	No connection.

Note 1: This board also could provide TFT panel backlight driving current by provide LED+ =5V & LED-=GND.Please contact Bolymin's sales for this function.